

EXPERIMENTAL INVESTIGATION OF THE REINER CENTRIPETAL EFFECT IN LIQUIDS

A. A. Sharts

UDC 532.513.1

The Reiner effect [1, 2] consists in the appearance of an excess pressure in the gap between two parallel coaxial disks, one of which is rotating while the other is fixed, under the condition that the gap is sufficiently small and that the rate of rotation is sufficiently great. This phenomenon is of special interest, since its study permits an experimental investigation of questions of anomalous (from the point of view of classical hydrodynamics) flows of liquids, having a typically Newtonian viscosity. This effect is connected with the behavior of liquid lubricating films in face seals (so-called "inside pumping").

Up to the present time, the effect has remained little studied, in view of the complexity of making the required measurements correctly and the lack of traditional engineering methods of investigation; thus, for example, measurement of pressures using Pitot tubes or built-in piezo pickups clearly breaks down the microgeometry of small gaps. The investigators [2-5] arrived at completely different points of view with respect to the nature of the effect or acknowledged the impossibility of drawing definite conclusions from the results obtained [6].

The constancy of the value of the gap during the course of the experiment made it possible to observe a replacement of the centrifugal effect by a centripetal effect, i.e., a change in the behavior of the liquid in the gap with a rise in the pressure gradient, while, at the same time, as for other investigators, a compressive force was applied to the disks, and the value of the gap was measured as a function of the rate of rotation. In the present work, the use of an interference method reduces to measurement of the shift of interference bands, recorded on a photographic film with the imposition of bundles of highly coherent light, reflected from a semi-transparent surface and the mirror-type lower surface of the transparent fixed disk, made up of two layers (glass and a hardened epoxide resin on the side of the gap), which are in optical contact at their interface. With a change in the pressure in the gap, the interference bands are shifted, since, under these conditions, there is a change in the refractive index of the epoxide resin.

The structure of the fixed disk is shown in Fig. 1, where 1 and 2 are interfering bundles of light; 3 is a glass, preventing sagging of the layer of resin; 4 is a semitransparent coating; 5 is a layer of epoxide resin, optically sensitive to the pressure; and 6 is a sector-shaped mirror resin coating.

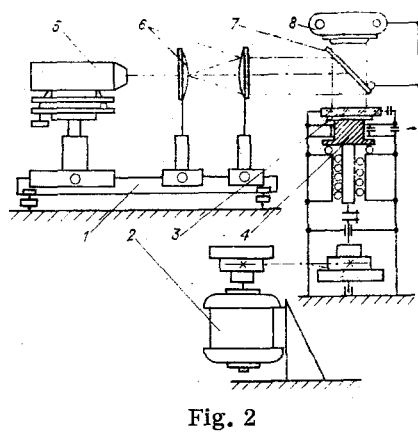
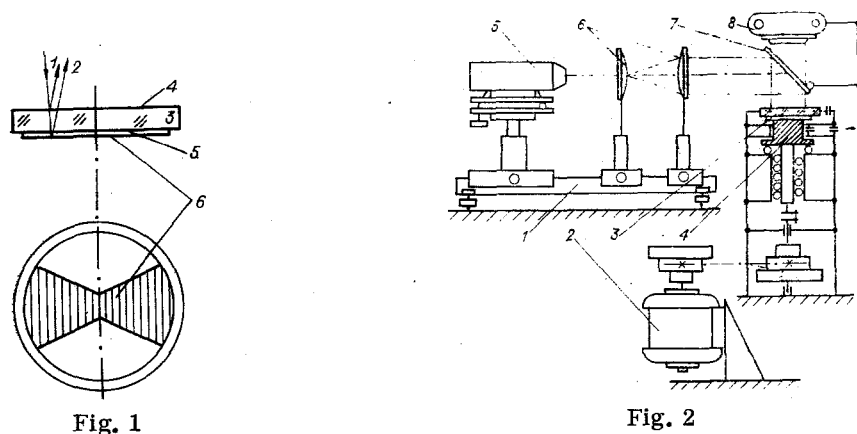

Moscow. Translated from Zhurnal Prikladnoi Mekhaniki i Tekhnicheskoi Fiziki, No. 2, pp. 105-109, March-April, 1977. Original article submitted February 20, 1976.

This material is protected by copyright registered in the name of Plenum Publishing Corporation, 227 West 17th Street, New York, N.Y. 10011. No part of this publication may be reproduced, stored in a retrieval system, or transmitted, in any form or by any means, electronic, mechanical, photocopying, microfilming, recording or otherwise, without written permission of the publisher. A copy of this article is available from the publisher for \$7.50.

TABLE 1

w r/R	15,7	23,0	34,6	59,8	71,4	122	136	152	168
0,03	-30	-56	-1	18	27	45	65	76	68
0,09	-24	-52	3	27	32	54	67	80	72
0,15	-27	-50	5	27	32	58	68	89	73
0,22	-27	-53	3	21	26	60	76	87	85
0,27	-25	-50	11	23	30	58	77	87	84
0,33	-21	-40	7	29	30	64	80	88	93
0,40	-20	-36	16	30	37	70	84	103	107
0,46	-15	-33	19	34	37	75	95	107	117
0,52	-12	-29	17	36	42	72	85	99	109
0,58	-12	-29	7	26	27	60	77	89	103
0,64	-16	-24	8	26	28	68	84	92	107
0,70	-15	-25	5	25	25	67	83	96	103
0,75	-13	-23	5	25	25	61	78	85	104
0,80	-6	-15	3	26	25	57	67	73	88
0,85	-6	-13	9	23	25	56	58	70	79
0,90	-10	-12	1	21	26	47	45	51	63
0,95	-7	-10	0	10	12	30	26	34	45
0,99	-3	-8	1	6	8	22	20	25	30

TABLE 2

w r/R	15,7	23,0	47,2	59,8	71,3	84,8	110	122	136	168
0,06	-27	-60	-98	-82	-50	-55	42	-10	-16	-20
0,13	-25	-52	-85	-71	-30	-30	52	0	5	3
0,19	-26	-49	-80	-62	-2	-18	58	10	12	26
0,25	-25	-44	-55	-62	-4	-4	57	23	29	50
0,32	-24	-39	-49	-43	-7	5	67	23	30	49
0,38	-21	-38	-53	-53	-3	1	62	24	25	39
0,44	-20	-40	-55	-45	-10	-4	51	20	25	35
0,51	-17	-33	-42	-42	-5	5	47	20	23	41
0,57	-16	-34	-45	-42	-11	4	34	12	16	32
0,63	-13	-31	-39	-39	-3	5	25	13	13	30
0,69	-13	-30	-40	-37	-8	-3	19	12	13	20
0,74	-12	-28	-30	-23	-10	-6	11	11	10	15
0,80	-12	-22	-20	-18	-13	-7	8	-1	6	11
0,85	-8	-16	-15	-16	1	-1	6	-3	8	15
0,90	-6	-10	-9	-9	-1	-2	-2	0	4	5
0,96	-3	-5	-5	-5	-1	-5	-2	0	0	5
1,00	0	0	0	0	0	0	0	0	0	-1

TABLE 3

w r/R	23,0	47,0	59,8	85,0	152	168	w r/R	23,0	47,0	59,8	85,0	152	168
0,04	-57	-47	7	21	43	113	0,53	-61	-51	-7	27	110	120
0,11	-58	-42	10	39	57	128	0,60	-60	-56	-1	14	84	108
0,17	-59	-47	-8	52	71	143	0,67	-60	-35	9	6	69	90
0,24	-70	-42	10	61	90	152	0,75	-58	-40	-5	-7	49	72
0,31	-50	-43	9	74	120	162	0,84	-42	-22	-4	-7	26	46
0,38	-57	-47	-4	48	122	146	0,92	-9	0	-2	5	12	19
0,45	-56	-50	7	41	110	131	1,00	3	2	-3	-3	0	0

As a result of the nonparallel character of the surfaces of the disk, the interference picture obtained from them has the form of parallel bands of equal thickness. The transparency of the disk is also used for optical adjustment of the value of the gap from Newton rings.

The overall scheme of the experimental unit is shown in Fig. 2, where 1 is an optical bench; 2 is an electric motor; 3 is the fixed disk; 4 is the rotating disk (base); 5 is a source of coherent light; 6 are lenses, forming a bundle of light; 7 is a semitransparent lens at an angle of 45° to the bundle of light; and 8 is a camera.

The total sag of the mechanical construction of the experimental unit did not exceed 1μ . The radius of the rotating disk $R=2.7$ mm. The class of cleanness of the surfaces of the disks was 13-14. The photography was done on film with 90 GOST (All-Union State Standard) units, with an exposure of 0.002-0.005 sec. The shift of the interference bands with respect to the initial band (beyond the limits of the gap) was measured in a UIM-21 measuring microscope. The sensitivity of the layer of resin with respect to the load was calibrated from the known distribution of the pressure.

Table 1 (gap in center 4μ ; at edge, 10μ) and Table 2 (gap in center 30μ ; at edge, 35μ) give the results of experiments with distilled water and Table 3 (gap in center 316μ ; at edge, 321μ) with a 50% alcohol-glycerine mixture. There are also shown the deviations of the pressure Δp in the gap from the external pressure, along the radius of the fixed disk, as a function of the angular rate of rotation of the second disk w . The pressure is measured in N/m^2 . The experiments were made at a temperature of $20^\circ C$.

In all the experiments, with the attainment of a sufficiently high rate of rotation, the centrifugal effect was replaced by a centripetal effect, which can be seen clearly from Tables 1-3 by the change in sign of the deviation of the pressure in the gap from the external pressure.

The first experiment was set up with the aim of observing the effect with a gap on the same order of magnitude as in the preceding investigations, but using a new method. The second experiment was made with the same liquid, but with a gap an order of magnitude greater, with the aim of clarifying the effect of the velocity gradient on the moment of the appearance of the effect. With calculation of the velocity gradient, account was taken of the change in the value of the gap from the center of the disks to the periphery (the warp of the disks) with respect to the Newton rings. The third experiment was made with another liquid, with a strongly differing viscosity and with a gap still an order of magnitude greater, with the aim of clarifying the effect of the viscosity on the appearance of the effect.

The centripetal effect, observed with gaps two orders of magnitude greater than with previous observations, cannot be attributed to the effect of small misalignments of the mechanical system, as has been done in [3-5].

The observed replacement of a centrifugal effect by a centripetal effect, i.e., the appearance of a lifting force of the layer of liquid in the gap between the disks with an increase in the velocity gradient permits making an attempt to use a theoretical evaluation of the upper limit of applicability of the Navier-Stokes equations from the critical value of the dimensionless parameter $\mu \kappa / p$, proposed in [7], where μ is the viscosity; κ is the velocity gradient; and p is the pressure.

If we calculate the value of the dimensionless parameter for the experimentally observed moments of the appearance of a centrifugal effect for different liquids and gaps, then, taking account of errors, it is found equal to $(7.3 \pm 0.9) \cdot 10^{-4}$. The equilibrium pressure in the calculation was taken as atmospheric.

Thus, the experimental results obtained demonstrate the applicability of the critical value of the dimensionless parameter for evaluating the character of the flow of a liquid.

The author expresses his thanks to Professor A. S. Akhmatov and Assistant Professor V. A. Bubnov for their valuable observations with evaluation of the work, as well as to Engineer M. V. Repkin for his invaluable aid in building the experimental unit.

LITERATURE CITED

1. M. Reiner, "The centripetal-pump effect in air," Proc. Roy. Soc., **A240**, 173 (1957).
2. M. Reiner, "Cross stresses in the laminar flow of liquids," Phys. Fluids, **3**, No. 3, 427 (1960).
3. D. F. Denny, "Some measurements of fluid pressure between plane-parallel thrust surfaces with special reference to the balancing of radial-face seal," Wear, **4**, No. 1, 64 (1961).
4. J. A. Findley, "Backpumping in mechanical face seals," Probl. Treniya Smazki, **91**, No. 3, 55 (1969).
5. B. S. Nau, "Hydrodynamic lubrication in face seal," in: Proceedings of the Third International Conference on Fluid Sealing (1967).
6. B. A. Batch and E. H. Iny, "Pressure generation in radial face seals," in: Proceedings of the Second International Fluid Sealing (1967).
7. K. Trusdell, "Exact upper limit of the correctness of the Navier-Stokes theory taking account of kinetic theory," in: Mekhanika [Periodic Collection of Translations of Foreign Articles], Vol. 4 (1970), p. 137.